

Bent axis hydraulic pumps

W

Series

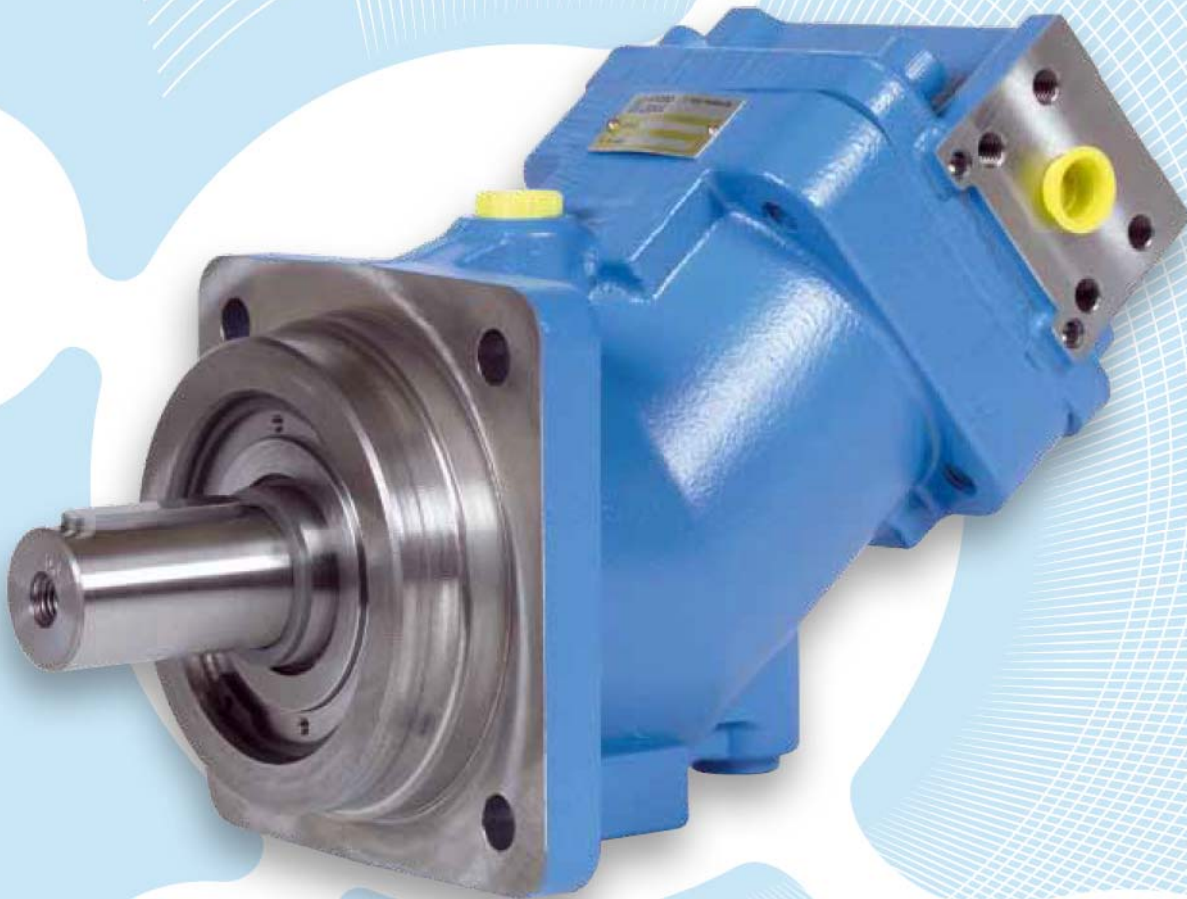

**HYDRO
LEDUC**
TOHIO[®]

Contents

■ Range and characteristics	1
■ Order code system	1
■ Dimensions	2
■ Performance	3
■ Installation and start-up recommendations	4
■ The complete LEDUC product range	5

W series pumps

The new W series bent axis piston pumps from LEDUC are of the most modern design, and exist in displacements from 12 to 108cc.

These W pumps were developed to satisfy the needs of both the industrial hydraulics market : hydraulic power packs, units for machine tools etc.; and of the mobile market : construction equipment, drilling machines, mobile cranes etc.

The following properties allow such a wide range of applications:

- the W pumps are self-priming and self-suction, which allows installation above the tank, for example, and makes start-up easier;
- capability of conveying fluids of various different types, and with a wide range of viscosities;
- drive speeds are from 150 rpm to over 3,000 rpm (for W12 and W18 models), thus allowing a wide control of flow as a function of pump rotating speed;
- capability of operating at continuous output pressures up to 350 bar (400 bar peak), whilst maintaining high global efficiency and low noise levels;
- W pumps are to standard interfaces : shaft, flange and ports are to European (ISO) standards, or North American (SAE) on request.

W pumps are the latest addition to the vast experience and production at HYDRO LEDUC of hydraulic pumps, motors and accumulators, all offering high performance and long service life.

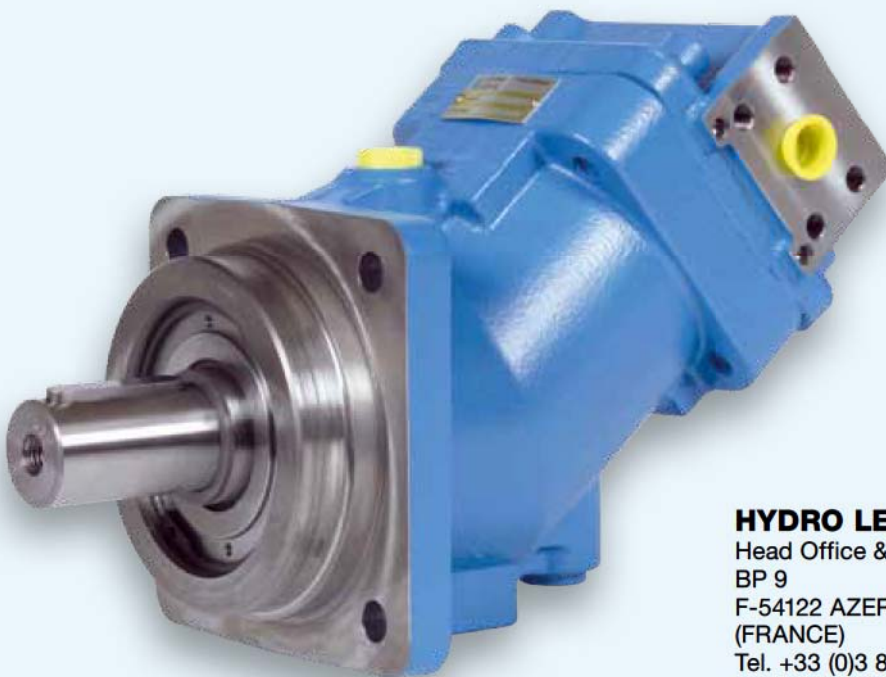

HYDRO LEDUC
Head Office & Factory
BP 9
F-54122 AZERAILLES
(FRANCE)
Tel. +33 (0)3 83 76 77 40
Fax +33 (0)3 83 75 21 58

Dimensions W series pumps

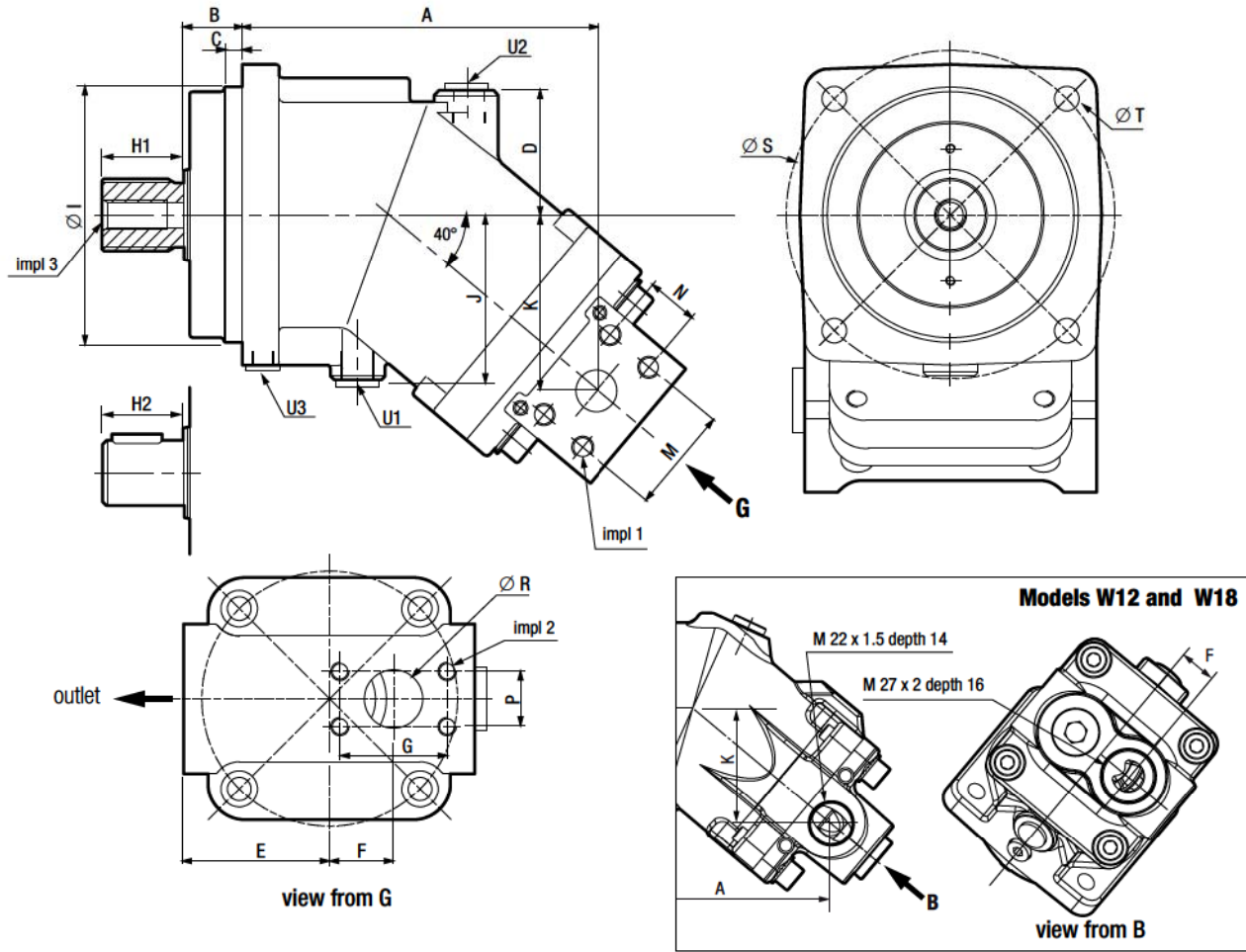

Pump model	A	B	C	D	E	F	G	I	J	K	M	N	P	R	S	T	U1	U2	U3
W12	123.0	20	6	39	44	17	-	80	51.5	58	-	-	-	-	100	9.0	M12x1.5	M12x1.5	M8x1
W18	123.0	20	6	39	44	17	-	80	51.5	58	-	-	-	-	100	9.0	M12x1.5	M12x1.5	M8x1
W25	146.6	25	8	56	60	22	47.6	100	68.0	69.8	40.5	18.2	22.2	19	125	11.0	M16x1.5	M16x1.5	M10x1
W32	152.7	25	8	56	60	22	47.6	100	69.0	73.7	40.5	18.2	22.2	19	125	11.0	M16x1.5	M16x1.5	M10x1
W41	152.7	25	8	56	60	22	47.6	100	69.0	73.7	40.5	18.2	22.2	19	125	11.0	M16x1.5	M16x1.5	M10x1
W50	172.2	32	10	59	68	30	52.4	125	84.0	88.2	50.8	23.8	26.2	25	160	13.5	M18x1.5	M18x1.5	M12x1.5
W63	172.2	32	10	59	68	30	52.4	125	84.0	88.2	50.8	23.8	26.2	25	160	13.5	M18x1.5	M18x1.5	M12x1.5
W80	200.2	32	10	68	80	35	58.7	140	90.5	101.6	57.2	27.8	30.2	32	180	13.5	M18x1.5	M18x1.5	M12x1.5
W90	200.2	32	10	68	80	35	58.7	140	90.5	101.6	57.2	27.8	30.2	32	180	13.5	M18x1.5	M18x1.5	M12x1.5
W108	200.2	32	10	68	80	35	58.7	140	90.5	101.6	57.2	27.8	30.2	32	180	13.5	M18x1.5	M18x1.5	M12x1.5

Pump model	splined shaft	H1	cylindrical keyed shaft	H2	outlet 6000 PSI	inlet 3000 PSI	Impl 1	Impl 2	Impl 3
W12	W25x1.25x30x18x9g	28	Ø25 (8 x 7 x 32)	40	M22x1.5	M27x2	-	-	M8
W18	W25x1.25x30x18x9g	28	Ø25 (8 x 7 x 32)	40	M22x1.5	M27x2	-	-	M8
W25	W25x1.25x30x18x9g	43	Ø25 (8 x 7 x 40)	50	SAE ½"	SAE ¾"	M8x1.25 prof 15	M10x1.5 prof 17	M8
W32	W30x2x30x14x9g	35	Ø30 (8 x 7 x 40)	50	SAE ½"	SAE ¾"	M8x1.25 prof 15	M10x1.5 prof 17	M10
W41	W30x2x30x14x9g	35	Ø30 (8 x 7 x 40)	50	SAE ½"	SAE ¾"	M8x1.25 prof 15	M10x1.5 prof 17	M10
W50	W35x2x30x16x9g	40	Ø35 (10 x 7 x 50)	60	SAE ¾"	SAE 1"	M10x1.5 prof 17	M10x1.5 prof 17	M12
W63	W35x2x30x16x9g	40	Ø35 (10 x 7 x 50)	60	SAE ¾"	SAE 1"	M10x1.5 prof 17	M10x1.5 prof 17	M12
W80	W40x2x30x18x9g	50	Ø40 (12 x 8 x 56)	70	SAE 1"	SAE 1¼"	M12x1.75 prof 20	M10x1.5 prof 17	M16
W90	W40x2x30x18x9g	50	Ø40 (12 x 8 x 56)	70	SAE 1"	SAE 1¼"	M12x1.75 prof 20	M10x1.5 prof 17	M16
W108	W40x2x30x18x9g	50	Ø40 (12 x 8 x 56)	70	SAE 1"	SAE 1¼"	M12x1.75 prof 20	M10x1.5 prof 17	M16

Performance W series pumps

Torque absorbed as function of pump outlet pressure

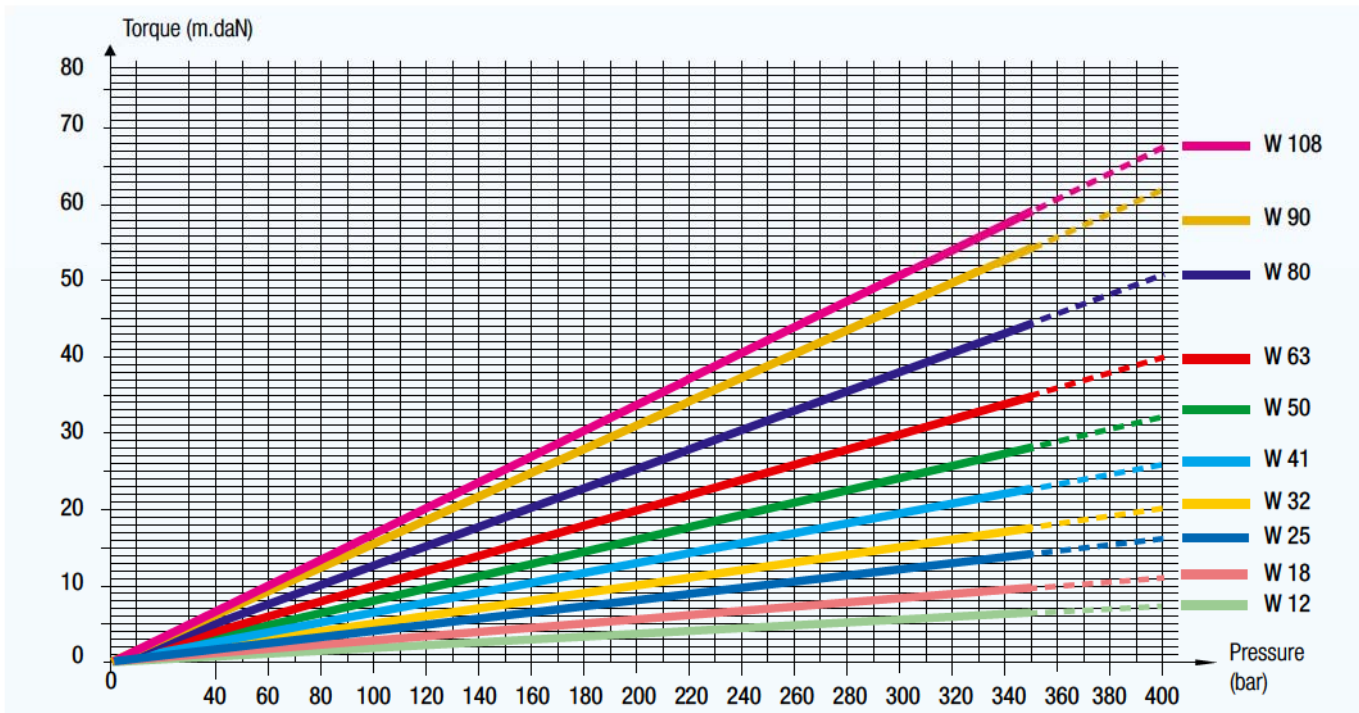

Flow

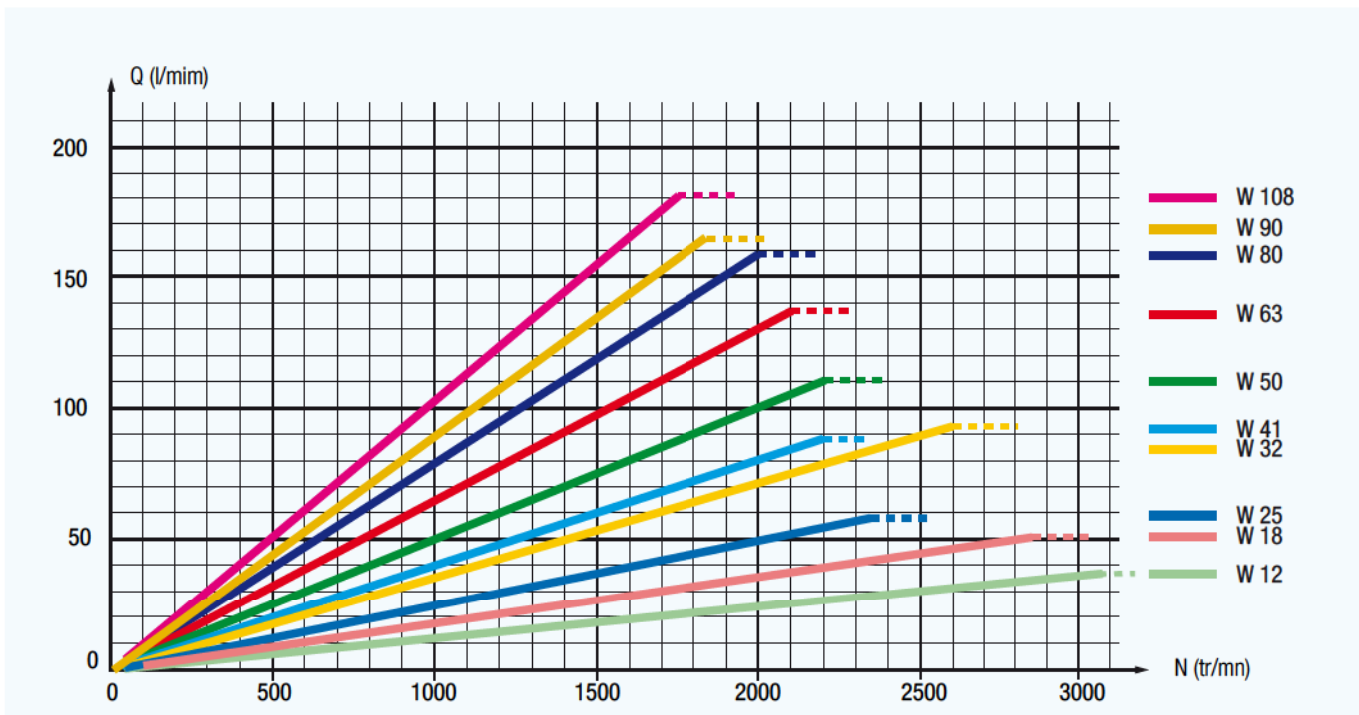

Volumetric efficiency

These graphs are the results of testwork done in the HL R&D laboratory, on a specific test bench, with an ISO 46 fluid at 25°C (100 cSt), the pump is supplied through a 2" diameter, 4 meters long hosing, and tank situated slightly above pump.

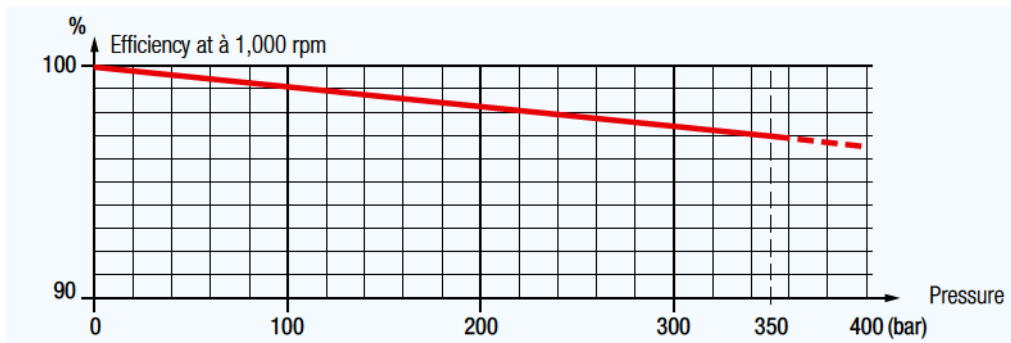

Installation and start-up W series pumps

Hydraulic fluid

LEDUC pumps are designed to be used with mineral-based hydraulic fluids. The use of other fluids is possible but may require the pump to be adapted, please consult our Technical Department.

Recommended viscosity:

- between 20 and 40 cSt : within this range the pumps will perform according to the characteristics given;
- minimum viscosity : 5 cSt;
- maximum viscosity : 400 cSt.

Filtration of hydraulic fluid

The service life of the pump depends on the quality and cleanliness of the fluid used. Recommended filtration : 10 μ absolute.

We recommend minimum cleanliness as follows:

- class 9 according to NAS 1638;
- class 6 according to SAE;
- class 18/15 according to ISO standard.

Acceptable forces on W pump shaft

It is preferable to avoid having any radial or axial force on the W pump shaft. If it is not possible, check in table below for maximum acceptable force.

Fr : radial force at mid length of shaft,

Fa : axial force which tends to push the pump shaft inwards.

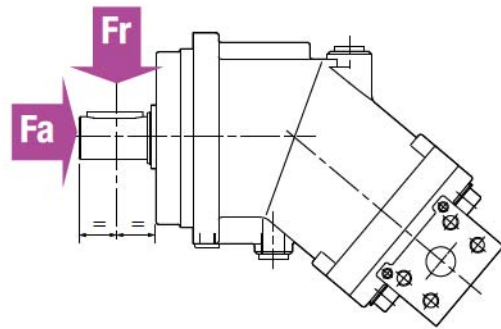

displacement	cc	12	18	25	32	41	50	63	80	90	108
Fr	N	4000	4000	6000	6500	7000	4000	5000	6500	6700	7000
Fa	N/bar	15	20	27	30	40	40	50	60	67	80

For other forces, please contact us.

Mounting position for W pumps

W pumps can be used in any position, but must have a drain, and pressure in the drain line must not exceed 2 bar.

The drain must be connected to the tank in the most direct way possible.

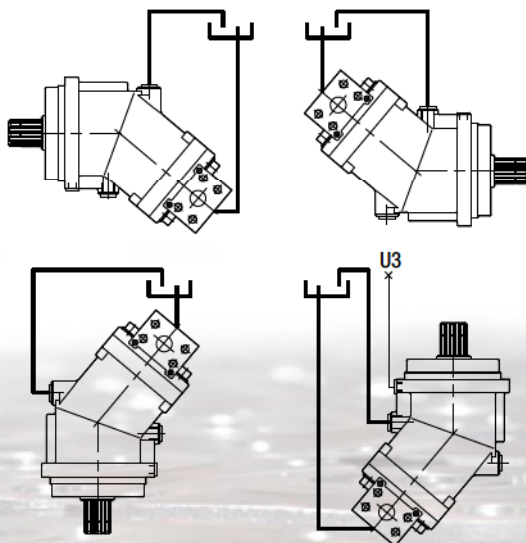

In installations where the position of the pump is above the tank, ensure the drain line is always underneath the fluid level tank.

If this is not the case, it is necessary to add a check valve on the drain line as shown in the figure below.

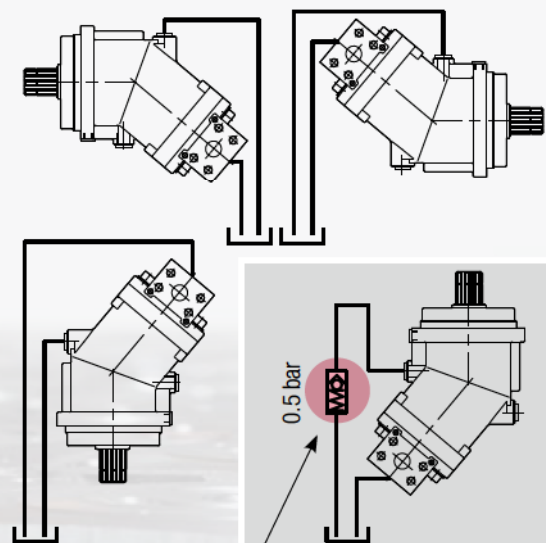

0.5 bar
ensure a ΔP of 0.3 to 0.5 bar

Assembly with check valve

Instructions for use

Each pump is supplied with an instruction leaflet, also available via e-mail on request mail@hydroeduc.com.

The complete range

hydraulic motors

Fixed displacement bent-axis pistons motors. Models from 12 to 126 cc. Available both in ISO and SAE versions.

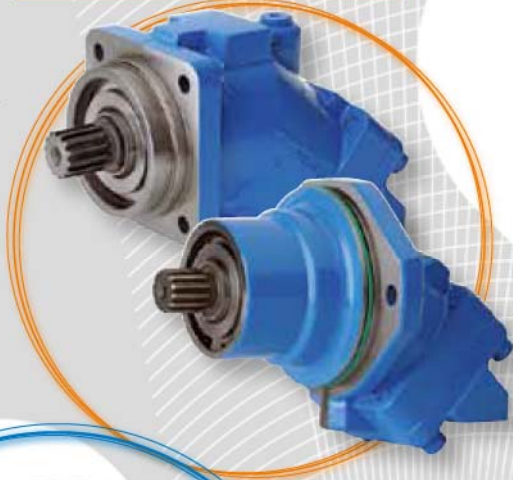

mobile and industrial pumps

Fixed displacement pumps, the W series, and variable displacement pumps, the DELTA series. High pressure capabilities within minimal size. **W** series: flanges to ISO 3019/2, shafts to DIN 5480. **DELTA** series: SAE shafts and flanges.



hydro-pneumatic accumulators

Bladder, diaphragm accumulators. Spherical and cylindrical accumulators. Volume capacities from 20 cc to 50 liters. Pressures up to 500 bar. Accessories for use with hydraulic accumulators.

TXV

XP

PA
PAC
PAD

piston pumps for trucks

HYDRO LEDUC offers 3 types of piston pumps perfectly suited to all truck and PTO-mount applications. Fixed and variable displacement from 12 to 150 cc.

micro-hydraulics

This is a field of exceptional HYDRO LEDUC know-how:

- axial and radial piston pumps, of fixed and variable displacement,
- axial piston micro-hydraulic motors,
- micro-hydraulic units incorporating pump, electric motors, valving, controls, etc.

To users of hydraulic components which have to be housed in extremely small spaces, HYDRO LEDUC offers complete, original and reliable solutions for even the most difficult environments.



we are passionate about hydraulics...



A dedicated R&D team means HYDRO LEDUC is able to adapt or create products to meet specific customer requirements. Working in close cooperation with the decision-making teams of its customers, HYDRO LEDUC optimizes proposals based on the specifications submitted.

a passion for hydraulics

HYDRO LEDUC

Head Office & Factory
BP 9 - F-54122 AZERAILLES (FRANCE)
Tél. +33 (0)3 83 76 77 40
Fax +33 (0)3 83 75 21 58

HYDRO LEDUC GmbH

Haselwander Str. 5
D-77746 SCHUTTERWALD (DEUTSCHLAND)
Tel. +49 (0) 781-9482590
Fax +49 (0) 781-9482592

HYDRO LEDUC N.A., Inc.

19416 Park Row - Suite 170
HOUSTON, TEXAS 77084 (USA)
Tel. +1 281 679 9654
Fax +1 832 321 3553



Complete catalogues available at:
www.hydroleduc.com



HYDRO LEDUC

SAS with capital of 4 065 000 euros

Siret 319 027 421 00019

RC Nancy B 319 027 421

mail@hydroleduc.com

